

RSW1020H54D

Electrical Specification

Parameter	Symbol	Typical	Units
Frequency Bandwidth	B	1.0~2.0	GHz
Insertion Loss	IL	0.5, 1.0(max)	dB
Return Loss	RL	-15, -10(max)	dB
Isolation RFc to R1/R2	ISO1	40(min)	dB
Average Power Handling Capability at B	P _{in}	200, 250(max)	W
Switching Time (50 % control to 90 % RF)	t _{sw}	2.0, 5(max)	usec
MAX PRF of Control	f _c	1	kHz
RF Path for Control Low (0~0.8V)		RFc to RF1	
RF Path for Control High (4~5V)		RFc to RF2	
DC Power		28	V
Current Consumption		200, 250 (MAX)	mA
DC power and Control Connector type		22-05-7055 MOLEX	
MOLEX Pin Configuration		1:Control (0~5V) 2:GND 3:NC 4:NC 5:VDD	
RF Connector Type		f-N type	
Size (w/o Connector Extension)		76X56X37	mm ³
Operating Case Temperature		-20~70	degree C
Storage Temperature		-40~90	degree C

- ※ Control Signal is normally pulled up.
- ※ Maximum source and load VSWR is 2.0 : 1 for maximum handling power .
- ※ Do not use out of band.
- ※ Do not use without proper DC Power.

Specifications subject to change without notice.

Customer Service: Tel. 82-31-708-7575

Email: kijeon@rfcore.com

<http://www.rfcore.com>

Mechanical Drawing

RSW1020H54D

units : mm

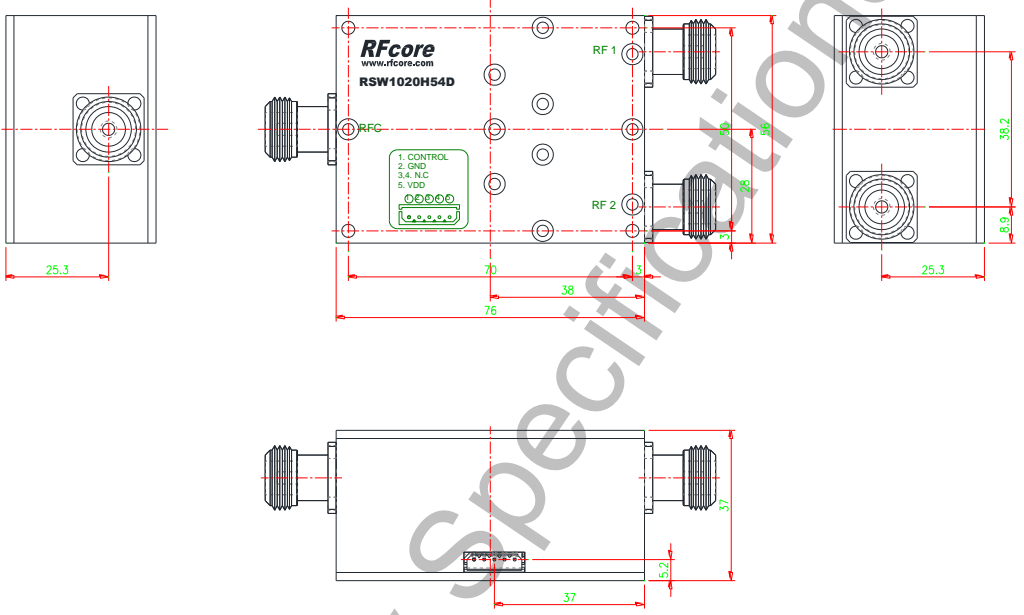

Preliminary Specifications

Specifications subject to change without notice.

Customer Service: Tel. 82-31-708-7575

Email: kijeon@rfcore.com

<http://www.rfcore.com>

